



ESP3185-3LCD2

8.5Gbps 1310nm 2KM SFP+ Optical Transceiver

Features

- Up to 8.5Gb/s bi-directional data links
- Hot Pluggable SFP+ footprint
- Built-in digital diagnostic functions
- 1310nm FP laser transmitter
- Duplex LC connector
- Up to 1.4km at 8.5Gb/s on 9/125um SMF
- Single 3.3V power supply
- Operating case temperature: 0 to 70°C
- RoHS6 compliant (lead free)

Applications

- Tri Rate 2.125/4.25/8.5Gbs Fiber Channel

Product description

ETU-Link's ESP3185-3LCD2 SFP+ transceivers are designed for use in Fibre Channel links up to 1.4 km at 8.5Gb/s data rate. They are compliant with FCPI-4 Rev. 8.00 and SFF-8472 Rev 10.2 and compatible with SFF-8431. ETU-Link's ESP3185-3LCD2 Digital diagnostics functions are available via a 2-wire serial interface, as specified in SFF-8472, which allows real-time access to device operating parameters such as transceiver temperature, laser bias current, transmitted optical power, received optical power and transceiver supply voltage. The product is RoHS compliant and lead-free per Directive 2002/95/EC

Absolute Maximum Ratings

Parameter	Symbol	Min	Typ	Max	Unit	Ref.
Maximum Supply Voltage	Vcc	-0.5		4.7	V	
Storage Temperature	TS	-40		85	°C	
Case Operating Temperature	Tcase	-5		70	°C	

Electrical Characteristics (Tcase = -5 to 70°C, VCC = 3.14 to 3.46 Volts)

Parameter	Symbol	Min	Typ	Max	Unit	Ref.
Supply Voltage	Vcc	3.14	3.3	3.46	V	
Supply Current	Icc			300	mA	
Transmitter						



Input differential impedance	Rin		100		Ω	1
Single ended data input swing	Vin,pp	180		700	mV	
Transmit Disable Voltage	VD	Vcc-1.3		Vcc	V	
Transmit Enable Voltage	VEN	Vee		Vee+ 0.8	V	2
Transmit Disable Assert Time				10	us	
Receiver						
Differential data output swing	Vout,pp	300		850	mV	3
Data output rise time	tr	28			ps	4
Data output fall time	tf	28			ps	4
LOS Fault	VLOS fault	Vcc-1.3		VccHOST	V	5
LOS Normal	VLOS norm	Vee		Vee+0.8	V	5
Power Supply Rejection	PSR	100			mVpp	6

Notes:

- 1) Connected directly to TX data input pins. AC coupled thereafter.
- 2) Or open circuit.
- 3) Into 100 ohms differential termination.
- 4) 20 – 80 %.
- 5) Loss Of Signal is LVTTTL. Logic 0 indicates normal operation; logic 1 indicates no signal detected.
- 6) Receiver sensitivity is compliant with power supply sinusoidal modulation of 20 Hz to 1.5 MHz up to specified value applied through the recommended power supply filtering network.

Optical Characteristics ($T_{case} = -5$ to $70^{\circ}C$, $VCC = 3.14$ to 3.46 Volts)

Parameter	Symbol	Min	Typ	Max	Unit	Ref.
Transmitter						
Output Opt. Pwr	POUT	-6		0.5	dBm	1
Optical Wavelength	λ	1285	1310	1345	nm	
Wavelength Temperature Dependance			0.08	0.125	nm/ $^{\circ}C$	
Spectral Width (-20dB)	σ			1	nm	
Optical Extinction Ratio	ER	3.5			dB	
Transmitter and Dispersion Peanlty	TDP			3.2	dB	
Optical Rise/Fall Time	tr/ tf		0.1	0.26	ns	
RIN	RIN			-128	dB/Hz	
Output Eye Mask	Compliant with IEEE 0802.3ae					
Receiver						



Rx Sensitivity	RSENS			-15	dBm	2
Input Saturation Power (Overload)	Psat	0.5			dBm	
Wavelength Range	λ_c	1260		1360	nm	
LOS De -Assert	LOSD			-17	dBm	
LOS Assert	LOSA	-30			dBm	
LOS Hysteresis		0.5	1.0		dB	

Notes:

- 1) High Bandwidth Mode. Class 1 Laser Safety per FDA/CDRH and EN (IEC) 60825 regulations.
- 2) Also specified to meet curves in FC-PI-4 Rev 8.001 Figures 21, 22, and 23, which allow trade-off between wavelength, spectral width and OMA.
- 3) Equivalent extinction ratio specification for Fibre Channel. Allows smaller ER at higher average power.
- 4) For 8.5 Gb/s operation, Jitter values for gamma T and gamma R are controlled by TDP and stressed receiver sensitivity.
- 5) Measured with conformance signals defined in FC-PI-4 Rev. 8.00 specifications. Value in OMA. Measured with PRBS 27-1 at 10-12 BER.

Pin Assignment

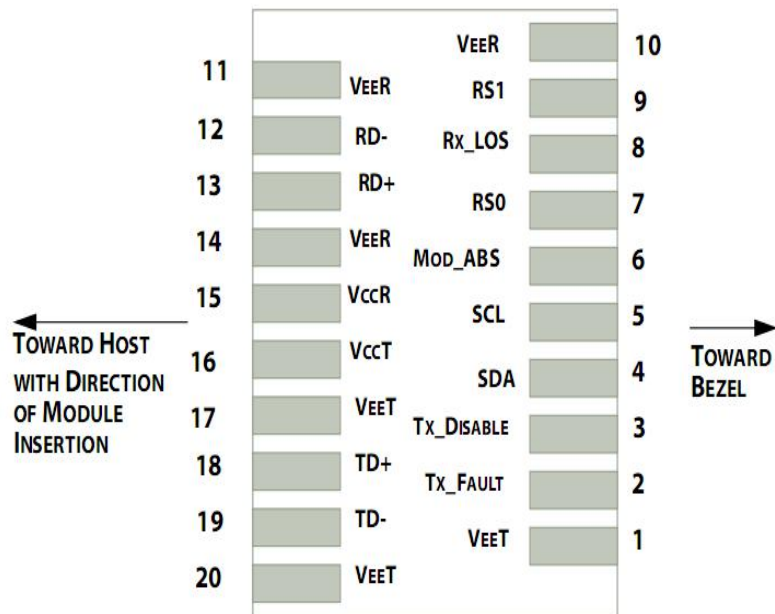

Pin out of Connector Block on Host Board

Pin	Symbol	Name/Description	Ref.
1	V _{EET}	Transmitter Ground (Common with Receiver Ground)	1
2	T _{FAULT}	Transmitter Fault.	2
3	T _{DIS}	Transmitter Disable. Laser output disabled on high or open.	3
4	SDA	2-wire Serial Interface Data Line	4



5	SCL	2-wire Serial Interface Clock Line	4
6	MOD_ABS	Module Absent. Grounded within the module	4
7	RS0	Rate Select 0	5
8	LOS	Loss of Signal indication. Logic 0 indicates normal operation.	6
9	RS1	No connection required	1
10	V _{EER}	Receiver Ground (Common with Transmitter Ground)	1
11	V _{EER}	Receiver Ground (Common with Transmitter Ground)	1
12	RD-	Receiver Inverted DATA out. AC Coupled	
13	RD+	Receiver Non-inverted DATA out. AC Coupled	
14	V _{EER}	Receiver Ground (Common with Transmitter Ground)	1
15	V _{CCR}	Receiver Power Supply	
16	V _{CCT}	Transmitter Power Supply	
17	V _{EET}	Transmitter Ground (Common with Receiver Ground)	1
18	TD+	Transmitter Non-Inverted DATA in. AC Coupled.	
19	TD-	Transmitter Inverted DATA in. AC Coupled.	
20	V _{EET}	Transmitter Ground (Common with Receiver Ground)	1

Notes:

- 1) Circuit ground is internally isolated from chassis ground.
- 2) T_{FAULT} is an open collector/drain output, which should be pulled up with a 4.7k – 10k Ohms resistor on the host board if intended for use. Pull up voltage should be between 2.0V to Vcc + 0.3V. A high output indicates a transmitter fault caused by either the TX bias current or the TX output power exceeding the preset alarm thresholds. A low output indicates normal operation. In the low state, the output is pulled to <0.8V.
- 3) Laser output disabled on T_{DIS} >2.0V or open, enabled on T_{DIS} <0.8V.
- 4) Should be pulled up with 4.7kΩ- 10kΩ host board to a voltage between 2.0V and 3.6V. MOD_ABS pulls line low to indicate module is plugged in.
- 5) Internally pulled down per SFF-8431 Rev 4.1.
- 6) LOS is open collector output. It should be pulled up with 4.7kΩ – 10kΩ on host board to a voltage between 2.0V and 3.6V. Logic 0 indicates normal operation; logic 1 indicates loss of signal.

Digital Diagnostic Functions

ETU-LINK's ESP3185-3LCD2 transceivers support the 2-wire serial communication protocol as defined in the SFP MSA1.

The standard SFP serial ID provides access to identification information that describes the transceiver's capabilities, standard interfaces, manufacturer, and other information.

Additionally, ETU-LINK SFP+ transceivers provide a unique enhanced digital diagnostic monitoring interface, which allows real-time access to device operating parameters such as transceiver temperature, laser bias current, transmitted optical power, received optical power and transceiver supply voltage. It also defines a sophisticated system of alarm and warning flags, which alerts end-users when particular operating parameters are outside of a factory set normal range.



The SFP MSA defines a 256-byte memory map in EEPROM that is accessible over a 2-wire serial interface at the 8 bit address 1010000X (A0h).The digital diagnostic monitoring interface makes use of the 8 bit address 1010001X (A2h), so the originally defined serial ID memory map remains unchanged.

The operating and diagnostics information is monitored and reported by a Digital Diagnostics Transceiver Controller (DDTC) inside the transceiver, which is accessed through a 2-wire serial interface. When the serial protocol is activated, the serial clock signal (SCL, Mod Def 1) is generated by the host. The positive edge clocks data into the SFP transceiver into those segments of the E2PROM that are not write-protected. The negative edge clocks data from the SFP transceiver.

The serial data signal (SDA, Mod Def 2) is bi-directional for serial data transfer. The host uses SDA in conjunction with SCL to mark the start and end of serial protocol activation. The memories are organized as a series of 8-bit data words that can be addressed individually or sequentially.

Host - Transceiver Interface Block Diagram

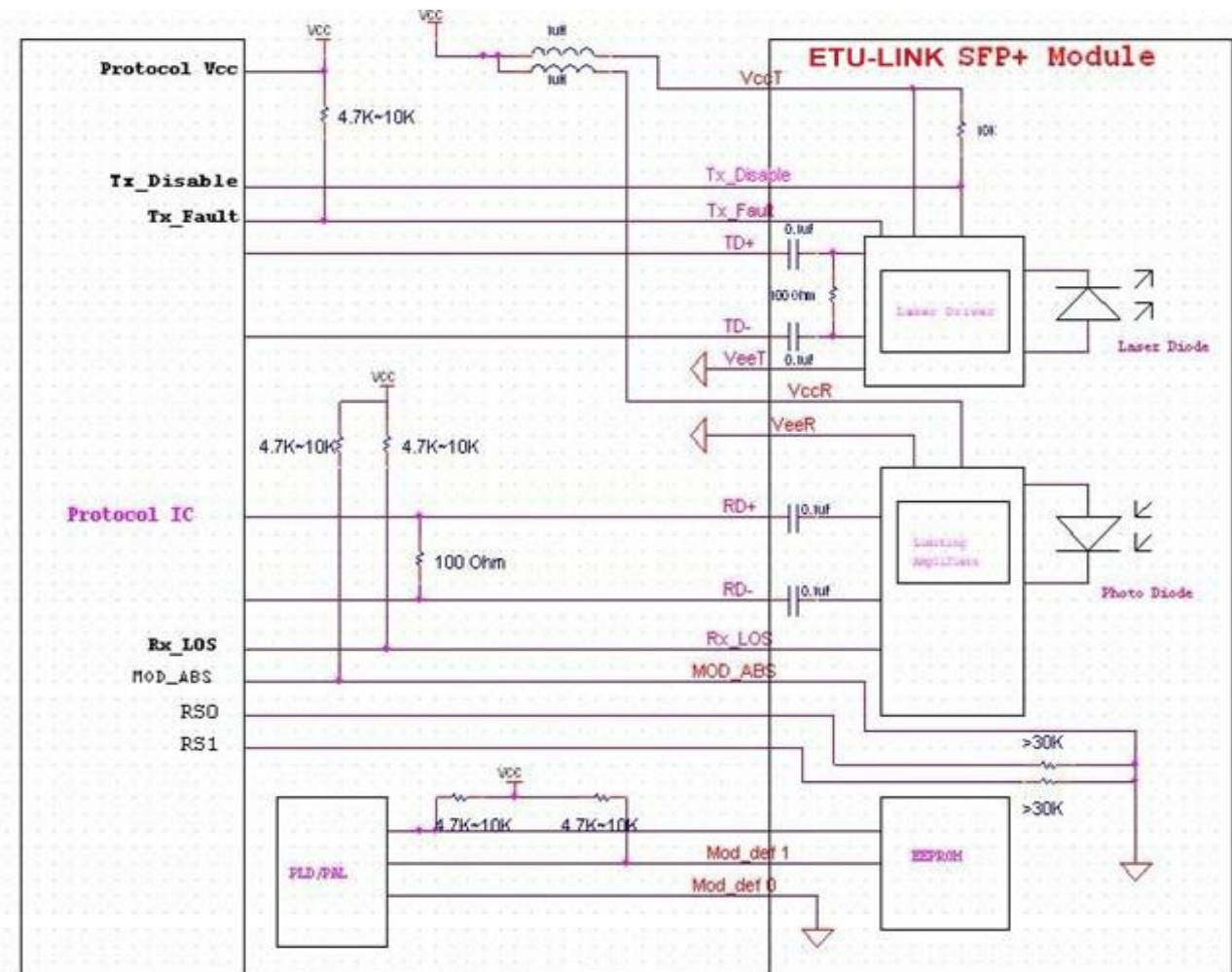



Outline Dimensions

Comply to SFF-8432 rev. 5.0, the improved Pluggable form factor specification.

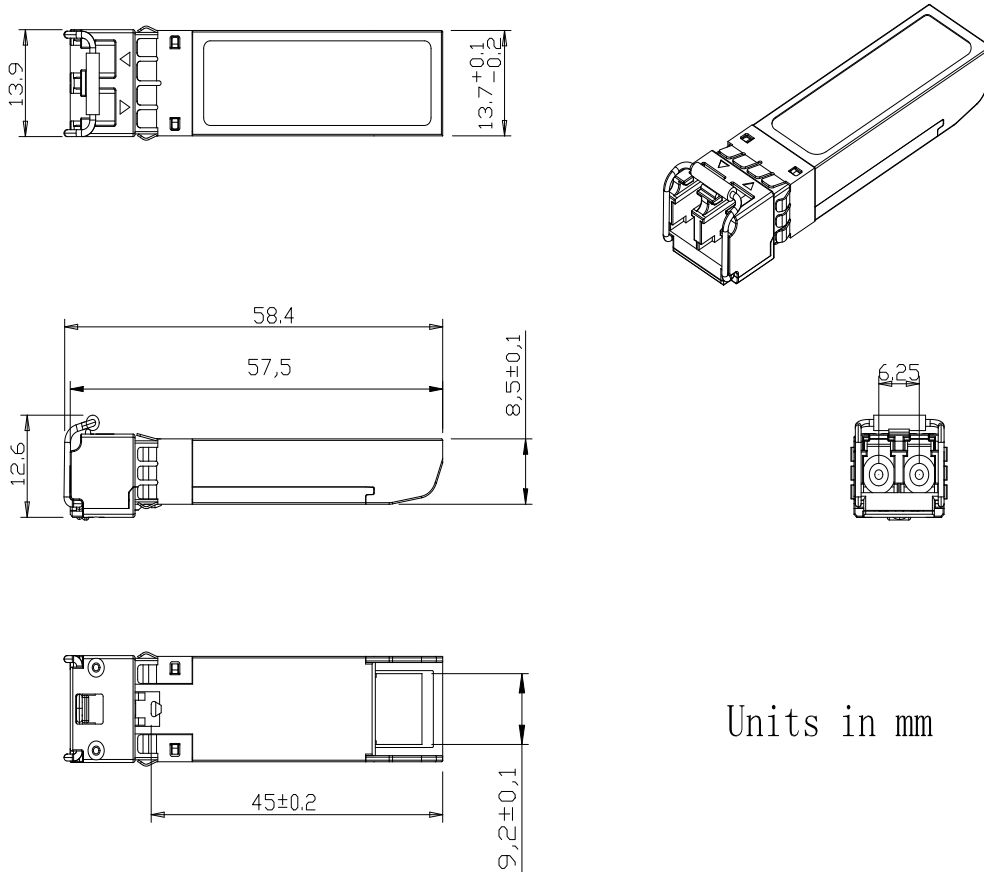

Units in mm

Regulatory Compliance

Feature	Reference	Performance
Electrostatic discharge (ESD)	IEC/EN 61000-4-2	Compatible with standards
Electromagnetic Interference (EMI)	FCC Part 15 Class B EN 55022 Class B (CISPR 22A)	Compatible with standards
Laser Eye Safety	FDA 21CFR 1040.10, 1040.11 IEC/EN 60825-1, 2	Class 1 laser product
Component Recognition	IEC/EN 60950, UL	Compatible with standards
ROHS	2002/95/EC	Compatible with standards
EMC	EN61000-3	Compatible with standards