



ECP28510A-3MCD01

100Gb/s CFP2 SR10 850nm 100m Optical Transceiver

Features

- Supports 103.1Gb/s to 112Gb/s bit rates
- Applicable for 100m with OM3 MMF and 150m with OM4 MMF
- MPO 24 receptacle optical interface
- CPPI electrical interface
- Uncooled 10x10Gb/s 850nm transmitter
- 10 parallel electrical serial interface
- Low power consumption <4W
- Digital Diagnostic Monitor Interface
- MDIO Communication Interface
- Compliant with 100GBASE-SR10
- Operating case temperature:
Commerical:0 to 70 °C



Applications

- 100GBASE-SR10 Ethernet
- 10x11.2Gb/s Multimode OTN
- 10x 10GE-SR Lite Ethernet

Standards

- Compliant with IEEE 802.3ba
- Compliant with CFP2 MSA hardware specifications
- Compliant with CFP2 MSA management specifications

General Description

ETU-LINK 100G CFP2 SR10 transceiver modules ECP28510A-3MCD01 are designed for use in 100 Gigabit Ethernet links and 10x11.2G OTN client interfaces over multimode fiber. They are compliant with the CFP2 MSA and with IEEE 802.3ba 100GBASE-SR10. Digital diagnostics functions are available via the MDIO interface.



Functional Diagram

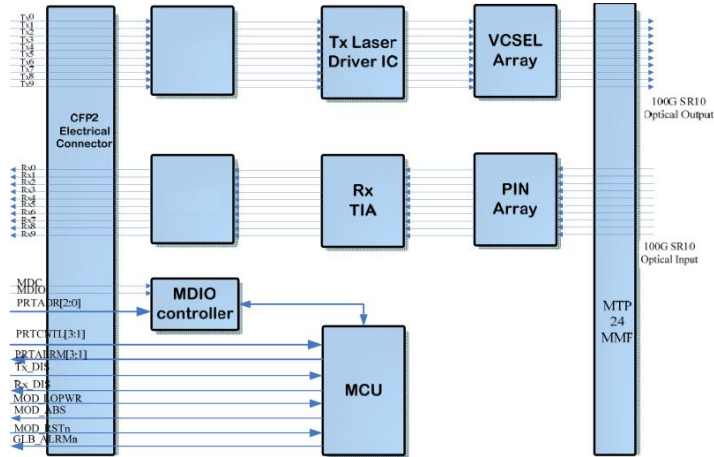

Figure 1. CFP2 SR10 Optical Transceiver functional block diagram

Absolute Maximum Ratings

Parameter	Symbol	Min.	Typ.	Max.	Unit	Note
Storage Temperature	Ts	-40	-	85	°C	
Relative Humidity	RH	0	-	85	%	
Power Supply Voltage	VCC	-0.5	-	3.6	V	
Signal Input Voltage		Vcc-0.3	-	Vcc+0.3	V	
Receive Input Optical Power (Damage threshold)	Pdmg			5.0	dBm	

Recommended Operating Conditions

Parameter	Symbol	Min.	Typ.	Max.	Unit	Note
Data Rate	DR		103	112	Gb/s	
Supply Voltage	Vcc	3.14		3.47	V	
Operating Case Temp.	Tc	0		70	°C	

Electrical Characteristics (TOP = 0 to 70°C, VCC = 3.13 to 3.47 V)

Parameter	Symbol	Min.	Typ	Max.	Unit	Note
Transmitter (per Lane)						
Data Rate Per Lane	DRPL		10.3125	11.1810	Gb/s	1



Input voltage tolerance	VIN	-0.3		4	V	
Differential data input swing	VIN,PP	120		1200	mVpp	2
Differential input threshold	VIN,TH		50		mV	
J2 Jitter Tolerance	JT2	0.17			UI	
J9 Jitter Tolerance	JT9	0.29			UI	
Receiver (per Lane)						
Output voltage	VOUT	-0.3		4.0	V	
Differential data output swing	VOUT,PP	300		800	mVpp	3
output voltage (RMS)	PSEN2			7.5	mV	
Termination mismatch at 1 MHx	PPx			5	%	
Output rise time and fall time	Tr, Tf		28		Ps	4
J2 Jitter output	JOT2			0.42	UI	
J9 Jitter output	JOT9			0.65	UI	
Power Supply Ripple Tolerance	PRS	Per CFP MSA			mVpp	

Notes:

1. +/- 100ppm at 10.3125 Gb/s and +/-20ppm at 11.1810 Gb/s.
2. After internal AC coupling. Self-biasing 100 Ω differential input.
3. AC coupled with 100 Ω differential output impedance. Limiting output.
4. 20%~80%

Optical Characteristics (TOP = 0 to 70 ° C, VCC = 3.13 to 3.47 V)

Parameter	Symbol	Min.	Typ	Max.	Unit	Note
Transmitter (per Lane)						
Data Rate Per Lane	DRPL		10.3125	11.1810	Gb/s	1
Center wavelength	λ	840	850	860	nm	
RMS Spectral Width	Δλ			0.65	nm	
Average Power per Lane	PAVEp	-8		1	dBm	
Transmit OMA per Lane	POMA	-6		3.0	dBm	2
Average launch Power of OFF	DP			-30	dB	
Peak Power per Lane	PP			4.0	dBm	
TDP per Lane	TDP			4	dBm	
Extinction Ratio	ER	3.0			dB	
Return Loss Tolerance				12	dB	
Relative Intensity Noise	RIN			-128	dB/Hz	3
Transmitter eye mask definition {X1, X2, X3, Y1, Y2, Y3}		0.23, 0.34, 0.43, 0.27, 0.35, 0.4				
Receiver (per Lane)						
Center wavelength	λ	840	850	860	nm	
Receiver Sensitivity per Lane	PSEN1			-9.9	dBm	4



Receiver Sensitivity (OMA) per Lane	PSEN2			-5.4	dBm	
Peak Power, per lane	PPx			4	dBm	
Overload, per lane	PAVE	1			dBm	
Receiver Reflectance	Rrx			-12	dB	
Dispersion penalty, per lane	TDP			1.9	dB	
Stressed eye J2 jitter, per Lane	JE2P		0.35		UI	
Stressed eye J9 jitter, per Lane	JE9P		0.47		UI	
Jitter tolerance [OMA], per lane	JTP		-5.4		dBm	
LOS De-Assert	Pa	-11			dBm	
LOS Assert	Pd			-25	dBm	
LOS Hysteresis	Pd-Pa	0.5			dB	

Notes:

1. Transmitter consists of 10 lasers operating at a maximum rate of 11.1810 Gb/s each.
2. Even if TDP is <0.9dB, the OMA min must exceed this value.
3. RIN is scaled by 10*log (10/4) to maintain SNR outside of transmitter.
4. Measured using DUT Tx and DUT Rx; no golden transmitters shall be used.

Optical lane assignment (front view of MPO receptacle)

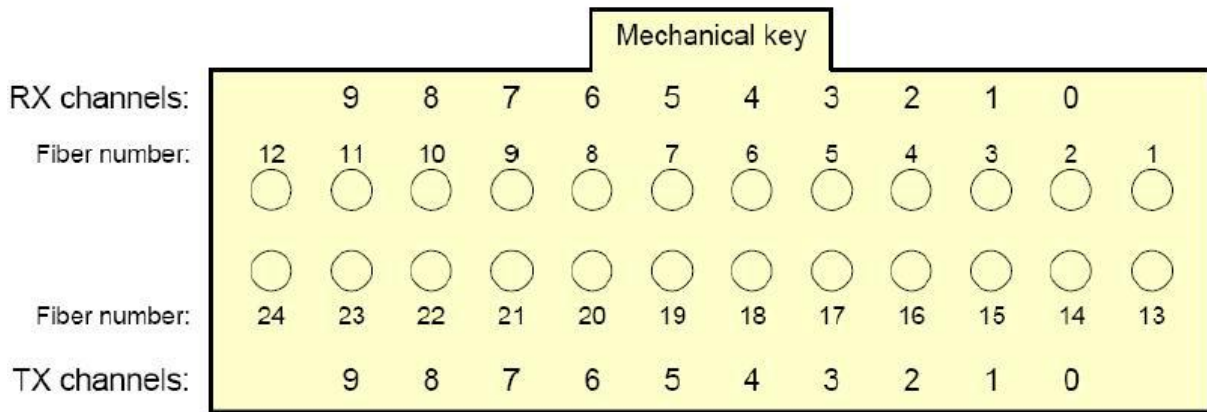

Fiber number	Channel	Electrical pin	Fiber number	Channel	Electrical pin
1	Unused		13	Unused	
2	RX0	54, 55	14	TX0	81, 82
3	RX1	57, 58	15	TX1	84, 85
4	RX2	60, 61	16	TX2	87, 88
5	RX3	63, 64	17	TX3	90, 91
6	RX4	66, 67	18	TX4	93, 94
7	RX5	69, 70	19	TX5	96, 97
8	RX6	72, 73	20	TX6	99, 100



® 深圳易天光通信有限公司

ETU-LINK TECHNOLOGY CO., LTD

9	RX7	75, 76	21	TX7	102, 103
10	RX8	51, 50	22	TX8	6, 5
11	RX9	48, 47	23	TX9	3, 2
12	Unused		24	Unused	

Pin Function Definitions

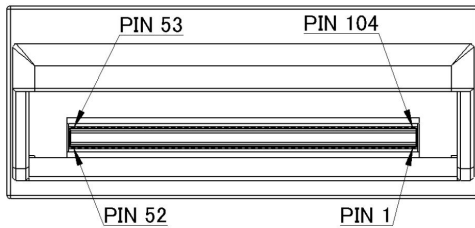

	CFP2		
	Bottom ALT1	Top ALT1	
1	GND	104	GND
2	II9 _m	103	II7 _m
3	II9 _p	102	II7 _p
4	GND	101	GND
5	II8 _m	100	II6 _m
6	II8 _p	99	II6 _p
7	GND	98	GND
8	3.3V_GND	97	II5 _m
9	3.3V	96	II5 _p
10	3.3V	95	GND
11	3.3V	94	II4 _m
12	3.3V	93	II4 _p
13	3.3V_GND	92	GND
14	3.3V_GND	91	II3 _m
15	VDD_IO_A	90	II3 _p
16	VDD_IO_B	89	GND
17	PRG_CN111	88	II2 _m
18	PRG_CN112	87	II2 _p
19	PRG_CN113	86	GND
20	PRG_AIN11	85	II1 _m
21	PRG_AIN12	84	II1 _p
22	PRG_AIN13	83	GND
23	GND	82	II0 _m
24	II_DIS	81	II0 _p
25	NI_IOS	80	GND
26	MOD_IOPWR	79	(REFCLK _m)
27	MOD_AES	78	(REFCLK _p)
28	MOD_RST _m	77	GND
29	GLE_AIN1 _m	76	NI7 _m
30	GND	75	NI7 _p
31	ND_C	74	GND
32	NDIO	73	NI6 _m
33	PR1ADR0	72	NI6 _p
34	PR1ADR1	71	GND
35	PR1ADR2	70	NI5 _m
36	VDD_IO_C	69	NI5 _p
37	VDD_IO_D	68	GND
38	VDD_IO_E	67	NI4 _m
39	3.3V_GND	66	NI4 _p
40	3.3V_GND	65	GND
41	3.3V	64	NI3 _m
42	3.3V	63	NI3 _p
43	3.3V	62	GND
44	3.3V	61	NI2 _m
45	3.3V_GND	60	NI2 _p
46	GND	59	GND
47	NI9 _m	58	NI1 _m
48	NI9 _p	57	NI1 _p
49	GND	56	GND
50	NI8 _m	55	NI0 _m
51	NI8 _p	54	NI0 _p
52	GND	53	GND

Figure 2 CFP2 optical transceiver pin-out



Table 1 CFP2 optical transceiver pin descriptions

PIN#	Description	PIN#	Description
1	GND	104	GND
2	TX9n	103	TX7n
3	TX9p	102	TX7p
4	GND	101	GND
5	TX8n	100	TX6n
6	TX8p	99	TX6p
7	3.3V_GND	98	GND
8	3.3V_GND	97	TX5n
9	3.3V	96	TX5p
10	3.3V	95	GND
11	3.3V	94	TX4n
12	3.3V	93	TX4p
13	3.3V_GND	92	GND
14	3.3V_GND	91	TX3n
15	VND_IO_A	90	TX3p
16	VND_IO_B	89	GND
17	PRG_CNTL1	88	TX2n
18	PRG_CNTL2	87	TX2p
19	PRG_CNTL3	86	GND
20	PRG_ALRM1	85	TX1n
21	PRG_ALRM2	84	TX1p
22	PRG_ALRM3	83	GND
23	GND	82	TX0n
24	TX_DIS	81	TX0p
25	RX_LOS	80	GND
26	MOD_LOPWR	79	(REFCLKn)
27	MOD_ABS	78	(REFCLKp)
28	MOD_RSTn	77	GND
29	GLB_ALRMn	76	RX7n
30	GND	75	RX7p
31	MDC	74	GND
32	MDIO	73	RX6n
33	PRTADRO	72	RX6p
34	PRTADR1	71	GND
35	PRTADR2	70	RX5n
36	VND_IO_C	69	RX5p
37	VND_IO_D	68	GND
38	VND_IO_E	67	RX4n
39	3.3V_GND	66	RX4p
40	3.3V_GND	65	GND
41	3.3V	64	RX3n
42	3.3V	63	RX3p
43	3.3V	62	GND



® 深圳易天光通信有限公司

ETU-LINK TECHNOLOGY CO., LTD

PIN#	Description	PIN#	Description
44	3.3V	61	RX2n
45	3.3V_GND	60	RX2p
46	3.3V_GND	59	GND
47	RX9n	58	RX1n
48	RX9p	57	RX1p
49	GND	56	GND
50	RX8n	55	RX0n
51	RX8p	54	RX0p
52	GND	53	GND

Outline Dimensions

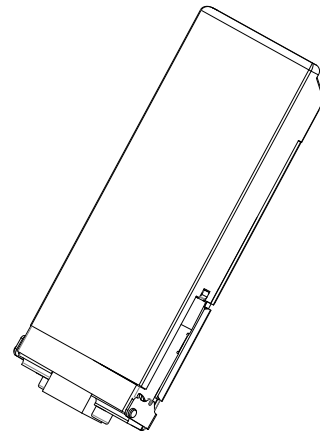
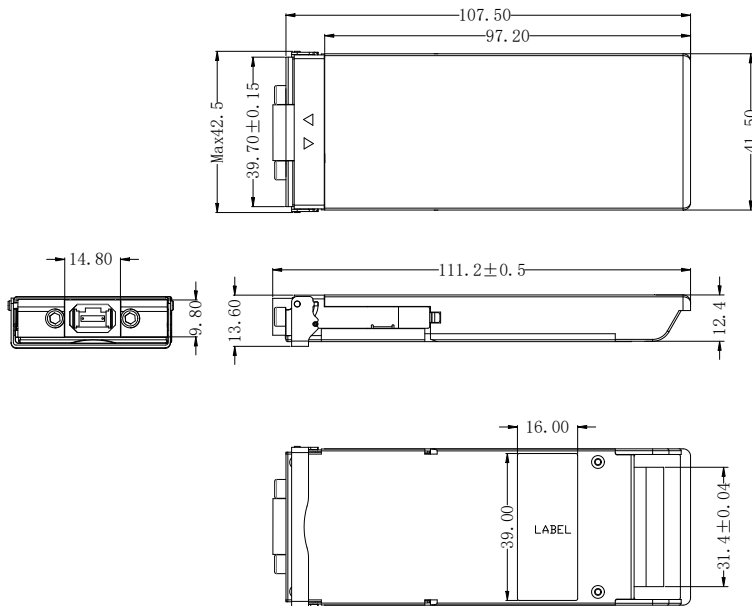

Units in mm

Tolerance without indication is $\pm 0.2\text{mm}$

Regulatory Compliance

Feature	Test Method	Performance
Electrostatic Discharge (ESD) to the Electrical Pins	MIL-STD-883E Method 3015.7	high speed signal pins shall withstand 500V electrostatic discharge based on Human Body Model per JEDEC JESD22-A114-B the other pins with exception of the high speed signal pins shall withstand 2kV electrostatic discharge based on Human Body Model per JEDEC JESD22-A114-B
Electrostatic Discharge (ESD) Immunity	IEC61000-4-2 Class B	15kV air discharges during operation and 8kV direct contact discharge



® 深圳易天光通信有限公司

ETU-LINK TECHNOLOGY CO., LTD

Electromagnetic Interference (EMI)	CISPR22 ITE Class B	Compliant with standard
------------------------------------	---------------------	-------------------------